

Proceedings
of the
Topical Meeting
on
Physics and Methods in Criticality Safety

Nashville, Tennessee
September 19-23, 1993

Sponsored by the American Nuclear Society's
Nuclear Criticality Safety Division and
the Oak Ridge/Knoxville Local Section

Cosponsored by the Department of Energy's
Oak Ridge Field Office, Martin Marietta
Energy Systems, Inc., and the
University of Tennessee

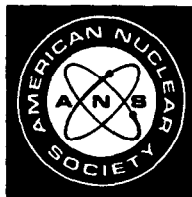

Published by the
American Nuclear Society, Inc.
La Grange Park, Illinois 60525 USA

Ref. 31

MEASUREMENTS WITH AN UNREFLECTED URANIUM (93.2%) METAL SPHERE

J. T. Mihalczo, J. J. Lynn^a, J. R. Taylor^a, and G. E. Hansen^b
Instrumentation and Controls Division
Oak Ridge National Laboratory^c
P.O. Box 2008
Oak Ridge, Tennessee 37831-6010
(615) 574-5577

ABSTRACT

A spherical unreflected and unmoderated uranium (93.2) metal configuration was assembled to delayed criticality at Oak Ridge National Laboratory in 1964 for measurements of leakage spectra and for investigation of the use of a multiplying booster with a linear accelerator. A variety of measurements was performed with this uranium metal sphere in addition to the delayed critical configurations. This paper describes in detail two configurations of the sphere for which all major parts had the same radius of curvature so that this experiment can be used to validate calculational methods and cross sections. The spherical critical mass obtained from these 3.4665-in.-radius experiments is slightly lower than that from previous measurements but within the experimental uncertainty.

INTRODUCTION

A near spherical unreflected and unmoderated uranium (93.7) metal configuration was assembled to delayed criticality at Los Alamos National Laboratory in the 1950s.¹ Experiments with highly enriched uranium metal spherical shells had also been assembled.¹ Both these experiments have been used to estimate the unreflected and unmoderated highly enriched uranium spherical critical mass. The experiments described in this paper, although originally justified for leakage spectra measurements and for investigation of the use of a multiplying booster with a linear accelerator, can also provide estimates of the unreflected and unmoderated highly enriched uranium spherical metal critical mass.

^aRetired from Oak Ridge National Laboratory.

^bLos Alamos National Laboratory, Los Alamos, New Mexico.

^cManaged by Martin Marietta Energy Systems, Inc., for the U.S. Department of Energy under contract DE-AC05-84OR21400.

The uranium metal sphere was assembled in various steps at the Critical Experiments Facility in Oak Ridge, Tennessee, to assure that a spherical near-critical configuration was ultimately achieved. This sphere was unreflected and unmoderated. The original purpose of the sphere was to measure the neutron leakage spectrum in a slightly subcritical system to validate calculational models. These measurements were performed at the LINAC at the General Atomic Company in San Diego in 1965. For these measurements the original sphere had a 1.000-in.-diam^a radial hole within 0.350 in. of the center to allow the beam from the linear accelerator to impinge on the uranium close to the center of the sphere. In 1971 and 1972 the sphere was modified by plugging the large radial hole, reducing the radius, and providing a variety of small holes for various reactor physics measurements that continued until 1975. At this time the sphere was returned to the Oak Ridge Y-12 Plant for reprocessing. There were essentially four configurations of the sphere, two earlier ones that were not exactly spherical and two later ones in which all major sphere parts had the same radius.

A variety of measurements was performed with this uranium metal sphere in addition to the delayed critical configurations. This system was assembled in a 35 × 35 × 30 ft high east cell of the Oak Ridge Critical Experiments Facility. The measurements performed with this sphere are as follows:

1. near delayed critical configuration,
2. surface worth of Oralloy,
3. central worth of Oralloy,
4. reactivity worth of structural materials supporting system,
5. surface worth of steel and aluminum,
6. room return effects,
7. prompt neutron decay constants,

^aLengths are given in inches, weights in grams, and density in grams per cubic centimeter since they were measured and reported in these units.

8. neutron leakage spectra,
9. spatial fission density distribution,
10. spatial importance distribution,
11. pulsed neutron and Rossi- α measurements vs reactivity, and
12. ^{252}Cf -source-driven noise analysis measurements vs reactivity.

This paper describes in detail the latter two configurations of the sphere for which all major parts had the same radius of curvature so that this experiment can be used to validate calculational methods and cross sections.

CONFIGURATION OF THE SPHERE PARTS

The sphere consisted of five major parts: a movable upper polar cap, an upper plate, a central plate, a lower plate, and a lower polar cap. In the first two configurations of the sphere, the central and upper plates and the lower plate and lower polar cap were held together with three stainless steel screws, and the central plate contained a 1.000-in.-diam radial hole to within 0.350 in. of the sphere center and a rectangular groove for a thermocouple.

The lower polar cap and a lower plate above it were moved by a piston with a range of motion of about 22 in. This lower section was mounted rigidly on a lightweight aluminum support stand that could be moved vertically and positioned the lower section 22 in. above the stainless steel table of a vertical assembly machine. The upper section of the lower part of the sphere had a cutoff alignment cone protruding at its center which fit into a recess in the central plate, thus assuring alignment when the two flat surfaces were adjacent. The central plate and the upper plate were also fastened together. The upper plate also had a cutoff alignment cone protruding at the center of the upper surface. The central section was supported with stainless steel tubing attached to the four vertical posts of the vertical assembly machine. The stainless steel tubing was attached by pins to a threaded steel part in the uranium. The length of the steel tubing could be adjusted to level the central section and position it exactly above the lower section. The upper polar cap was mounted through a flexible joint to a piston positioned above. The upper polar cap also had a recess for the cutoff alignment cone of the upper plate of the central piece. The assembly of the system was as follows. The upper polar cap was lowered until it rested on the central section. The lower section was then raised until it physically lifted the central and upper section ~ 0.020 in., thus assuring the contact and alignment of the three sections of the sphere. All Orallooy surfaces were machined to a surface finish of 32×10^{-6} in. All flat surfaces were machined flat to within 0.002-in. total indicator reading.

The isotopic composition and impurities in the enriched uranium metal are given in Tables 1 and 2. After return of the sphere from measurements at the General Atomic Company, the sphere was reassembled to delayed critical in 1970 at the Oak Ridge Critical Experiments

Facility. After various reactivity measurements of the surface worth, all parts were machined to an average radius of 3.4665 in. Before remachining the surface, the target hole in the central plate was filled with an enriched uranium metal plug. This plug was press-fit into the target hole. The press-fit part had a diameter of 0.9995 in., and thus the void introduced by the press-fit was 0.00025 in. on the radius. The central plate, after the target hole was filled, had a 0.136-in. diametral hole drilled through the center of the plug. The thermocouple groove at the upper surface of the central plate was filled with rectangular shaped Orallooy filler press-fit into the groove and machined. The three holes for the stainless steel screws holding the lower polar cap and the lower plate and the three holes for the screws holding the central and upper plates together were drilled out to a diameter of 0.453 in., and three highly enriched uranium pins were used to fasten the plates together by a press-fit of the pins into both pieces. From this time on, the sphere consisted of three main parts: the enlarged lower polar cap composed of the lower polar cap and lower plate, the central section composed of the central plate and the upper plate, and the upper polar cap, as shown in the photograph in Figure 1. The masses and dimensions of these parts for the 3.4665-in.-radius sphere are given in Table 3. The isotopic enrichment of the central plug and filler rods for the diametral hole are given in Table 1. Sketches of the parts for the 3.4665-in.-radius sphere are given in Figure 2. When assembled with the diametral hole empty and no surface mass adjustment buttons, this sphere had a positive reactivity of +60 cents as assembled at 24.5°C. The reactivity effect of adding an Orallooy 0.1293-in.-diam, 28.11-g filler rod to the diametral hole was $+11.23 \pm 0.07$ cents.

After reactivity measurements with the 3.4665-in.-radius sphere, the enlarged lower polar cap consisting of the lower plate and lower polar cap pinned together was machined to a radius of 3.439 in., and the sphere was reassembled for measurements. After these measurements the three major sphere sections were then remachined to an average radius of 3.4420 in. with the sphere center 0.020 in. above the previous center. As a result, the central diametral hole was 0.020 in. below the center of the sphere. The uranium density was measured hydrostatically and was 18.74, 18.74, and 18.72 g/cm³ for the upper, central, and lower sections of the sphere, respectively. The uranium density was also obtained from the dimensions and masses of the major pieces. The average Orallooy density from all determinations was 18.747 ± 0.005 g/cm³. The reactivity of this assembly with the diametral hole filled was -23 cents. The 3.4420-in.-radius sphere with the diametral hole filled with 28.11 g of filler rod and 16 surface mass adjustment buttons 0.250 in. thick (43.9 g each) had a reactivity of +12.4 cents at 24.5°C. Various additional holes were then machined into the central plate to accommodate a variety of ^{252}Cf sources and detectors, as shown in Figure 2. Plugs were provided so that all holes could be filled. The masses and dimensions of the three major sphere parts are given in Table 4. The isotopic enrichment of the filler plugs and split plugs that were used around the shafts of the small counter inserted into these holes is also given in Table 1.

Table 1 - Isotopic Enrichments of Oralloy for Major Sphere Parts, Plugs, Pins, and Other Small Uranium Metal Parts

| Description | Isotopic Enrichments (wt %) ^a | | | |
|---|--|--------------------|------------------|------------------|
| | ²³⁴ U | ²³⁵ U | ²³⁶ U | ²³⁸ U |
| Upper polar cap | 0.9844 | 93.21 ^b | 0.03593 | 5.76967 |
| Upper plate | 0.9844 | 93.21 ^b | 0.03593 | 5.76967 |
| Central plate | 0.9843 | 93.20 ^b | 0.03592 | 5.77978 |
| Lower plate | 0.9845 | 93.22 ^b | 0.03593 | 5.75957 |
| Lower polar cap | 0.9841 | 93.18 ^b | 0.03592 | 5.79998 |
| Mass adjustment buttons and upper socket (0.125 and 0.250 in. thick) | 0.9846 | 93.23 ^b | 0.03594 | 5.74946 |
| Plug for target hole | 0.9954 | 93.156 | 0.4510 | 5.3976 |
| Pins for central part | 0.9860 | 93.171 | 0.424 | 5.4190 |
| Pins for lower part | 0.9954 | 93.156 | 0.4510 | 5.3976 |
| Filler rods for 0.136-in.-diam diametral hole | 0.9954 | 93.156 | 0.4510 | 5.3976 |
| Plugs for 0.500-in.-diam holes ^c | 0.988 | 93.164 | 0.4460 | 5.4020 |
| Split plugs | 0.985 | 93.154 | 0.460 | 5.3880 |
| 0.063-in.-thick buttons | 0.9954 | 93.156 | 0.4510 | 5.3976 |

^aThese enrichments were from the average monthly enrichments of Oralloy parts made at the Y-12 Plant for the month in which the parts were fabricated except where noted. The ²³⁴U and ²³⁶U are known to $\pm 1\%$ and the ²³⁵U to four significant figures. The ²³⁸U percentage is by difference and is not accurate beyond the third digit.

^bMeasured and reported out.

^cSolid plugs were provided to fill all holes. Split filler plugs with inside diameters of 0.082 and 0.136 in. were provided to fit around the shafts of the various detectors and sources inserted into the 0.500-in.-radial and 0.375-in.-diam surface hole.

The measurements with the 3.4665- and 3.4420-in.-diam spheres were corrected for the reflection effects of nearby surrounding materials (14.8 cents) and the experimental cell (which was assumed to be the same as that from the indoor-outdoor measurements for GODIVA, 5 ± 3 cents), the internal voids within the sphere such as the void around the filler for the diametral hole and voids associated with the alignment cones and one of the pins in the lower section, and the holes into the sphere surface that were used to support the three major sphere sections and the surface mass adjustment buttons. The reactivity effects of the removal of the socket assembly for the upper section was measured directly (-10.2 cents). The reactivity effect of

inserting Oralloy into the hole for the upper socket was measured by first inserting and then removing three Oralloy 0.125-in.-thick surface mass adjustment buttons from this hole. The reactivity effect of the brass threaded into the lower section and the four stainless steel threaded pieces in the central section were obtained from reactivity coefficient measurements for GODIVA. The worth of the surface mass of Oralloy was obtained from the change in mass and reactivity of the two spheres and was 0.0794 cents/g of Oralloy. The critical mass obtained from these measurement on slightly higher than those from the GODIVA and Shell experiments as a result of enrichment and impurity differences.

Table 2 - Impurity Content of Enriched Uranium Sphere Parts

| ORNL Part No. | Part Description | Grams U per Gram (%) ^a | Boron Equivalent | Impurity Content (ppm) | | | | | | | | |
|---------------------|--|---|---------------------|------------------------|------|----|-----|--------------------------------------|-----|----|-----|------------------|
| | | | | Be | Li | Al | Si | Total Fe, Mn, Ni, Cr, V, Cu | B | Co | Ca | C |
| 1-6 | Upper polar cap | 99.961 | 0.647 | <0.01 | <0.2 | 6 | 80 | 85 | 0.5 | <1 | <10 | 202 |
| 1-8 | Upper plate | 99.966 | 0.408 | <0.01 | <0.2 | 4 | 100 | 34 | 0.3 | <1 | <10 | 159 |
| 1-10 | Central plate | 99.966 | 0.328 | <0.01 | <0.2 | 4 | 200 | 50 | 0.2 | <1 | <10 | 159 |
| 1-11 | Lower plate | 99.949 | 0.629 | <0.01 | <0.2 | 8 | 125 | 57 | 0.5 | <1 | <10 | 142 |
| 1-12 | Lower polar cap | 99.912 | 0.242 | <0.01 | <0.2 | 5 | 100 | 83 | 0.1 | <1 | <10 | 179 |
| 1-4 | 16 mass adjustment buttons, 0.025 in. thick | 99.955 | 0.348 | <0.01 | <0.2 | 2 | 200 | 68 | 0.2 | <1 | <10 | 306 ^b |
| 1-5 | 16 mass adjustment buttons, 0.125 in. thick | | | | | | | | | | | |
| 1-1 | Socket for upper polar cap | | | | | | | | | | | |

^aReported to 5 digits, accurate to 4 digits.

^bValues on this line are for part numbers 1-4, 1-5, and 1-1.

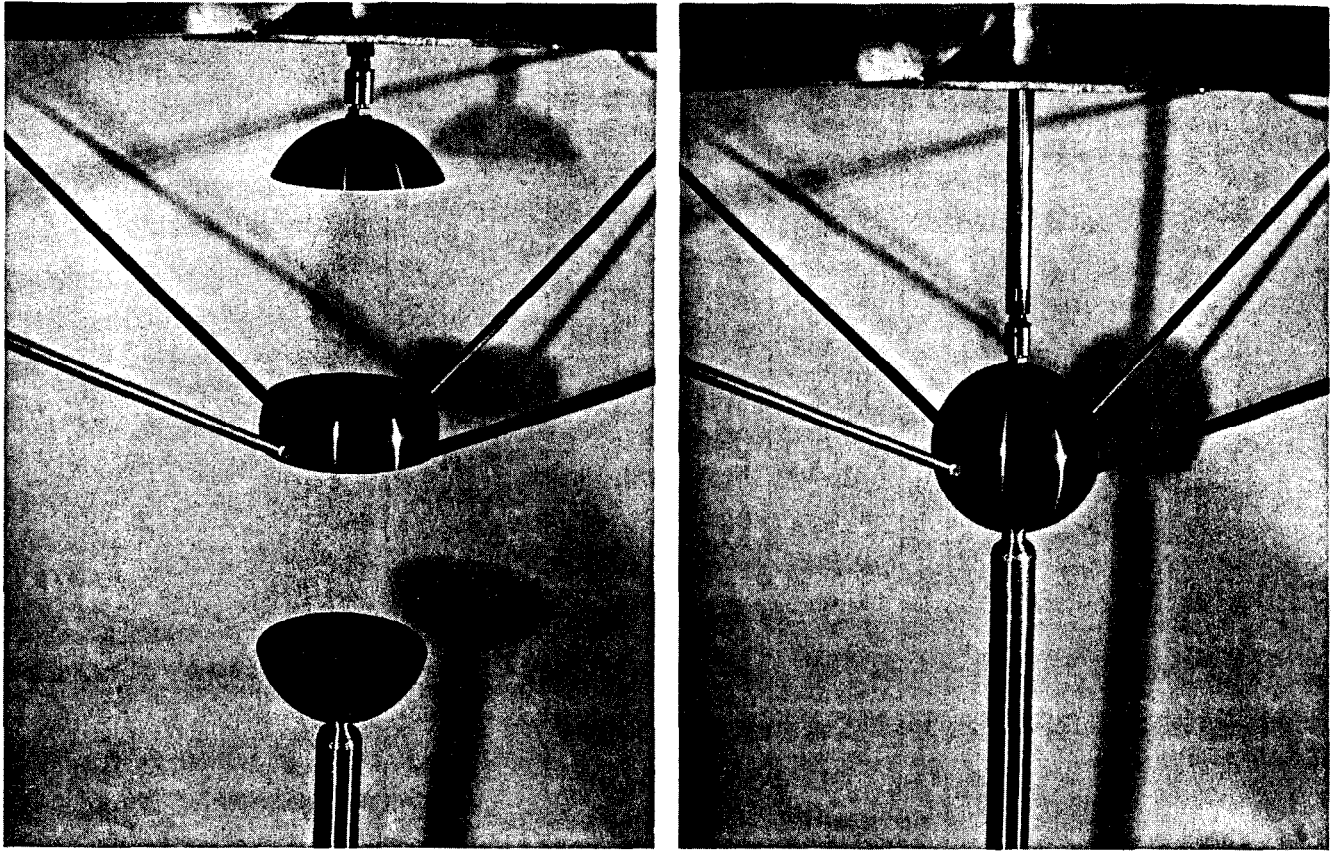

Figure 1 - Photograph of the 3.4420-in.-radius sphere in its disassembled and assembled condition.

Table 3 - Measured Radial Dimensions at 70°F and Certified Masses of 3.4665-in.-Radius Sphere Parts

| Section | Number of Points Measured | Deviation from 3.4670-in. Radius ^a (10 ⁻³ in.) | Vertical Height ^b (in.) | Certified Mass ^c (g) |
|-----------------|---------------------------|--|------------------------------------|---------------------------------|
| Upper polar cap | 6 | 0.0 at pole, +0.1, +0.1, +0.2, +0.4, +0.4 at bottom | 2.1375 | 12,042.76 ^d |
| Upper plate | 2 | -0.2 at top to -1.0 at bottom | 0.7662 | 21,095.06 ^e |
| Central plate | 2 | -0.2 at top to -1.0 at bottom | 1.1252 | |
| Lower plate | 4 | -0.8 at top, -0.8, -0.4 to 0.0 at bottom | 1.0383 | 10,610.27 |
| Lower polar cap | 6 | -1.8 at top, -1.6, -1.4, -1.0, -0.4, to -0.2 at pole | 1.8673 | 9,400.02 |

^aMeasured with a sweep gauge at 70°F at the Y-12 Plant. Multiple readings are equally spaced. Average radius is 3.4665 in., or 8.8049 cm.

^bThe radius obtained from the sum of vertical heights, divided by 2, is 3.4669 in., or 8.8059 cm.

^cThe sum of these certified masses is 53,148.11 g.

^dThis mass does not include the 64 g of uranium in the socket for attachment to the drive for the upper polar cap.

^eMass of upper and central plates after they were pinned together as one part with uranium metal pins. This mass does not include the 0.129-in.-diam, 4.265- and 2.745-in.-long filler rod for the 0.136-in.-diam diametral hole, which had masses of 17.117 and 11.046 g, respectively, and the uranium of the upper socket, which had a mass of 64 g. Thus, the total uranium mass of the sphere was 53,240.27 g, which includes the 64 g in the socket for the attachment of the upper polar cap to its piston rod.

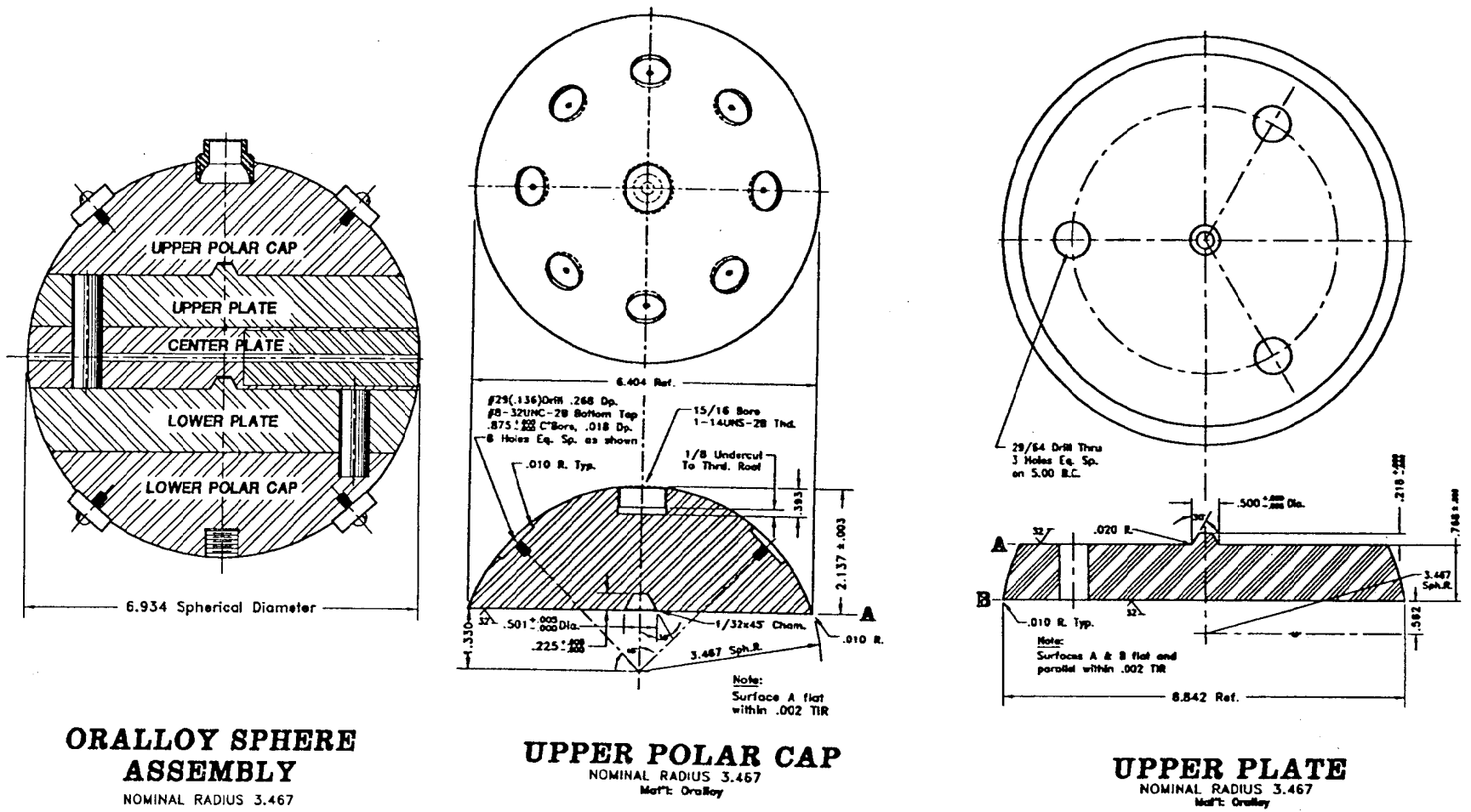
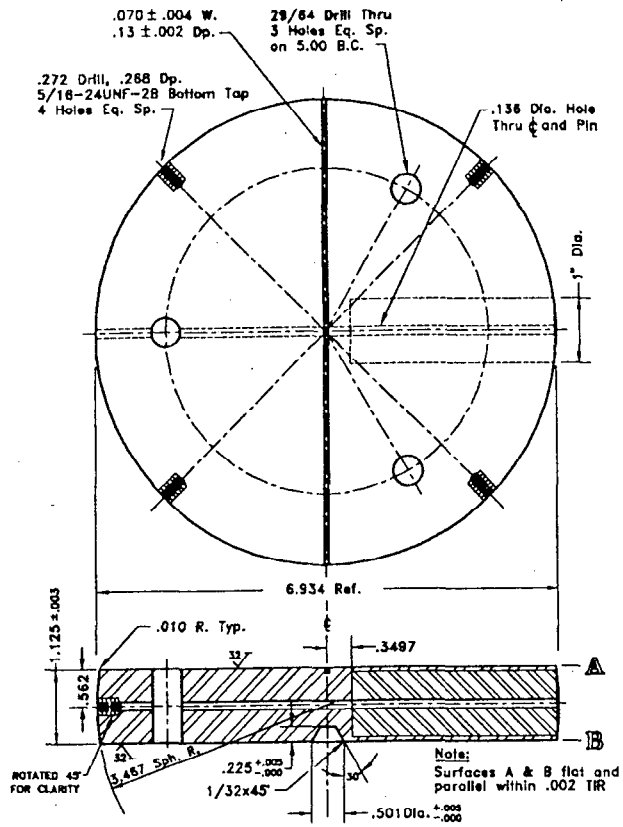
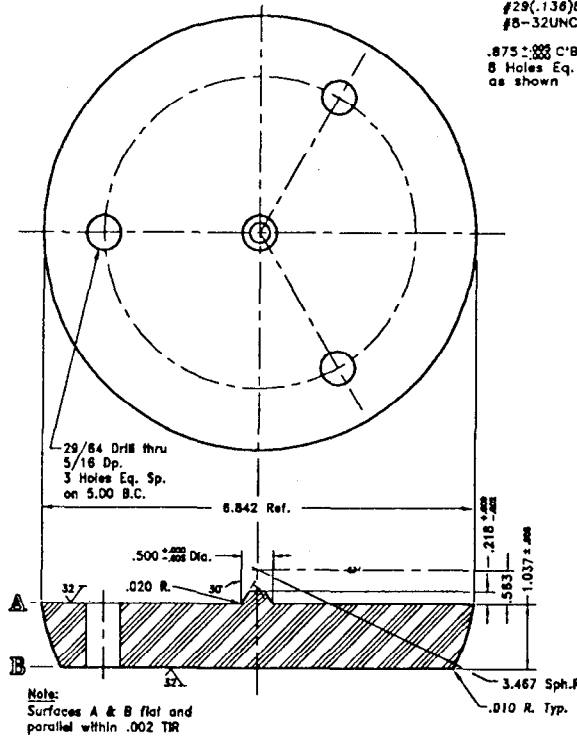

Figure 2 - Sketches of sphere parts with nominal radius of 3.467 in.



CENTER PLATE
 NOMINAL RADIUS 3.467
 Mat'l: Oracloy



LOWER PLATE
 NOMINAL RADIUS 3.467
 Mat'l: Oracloy

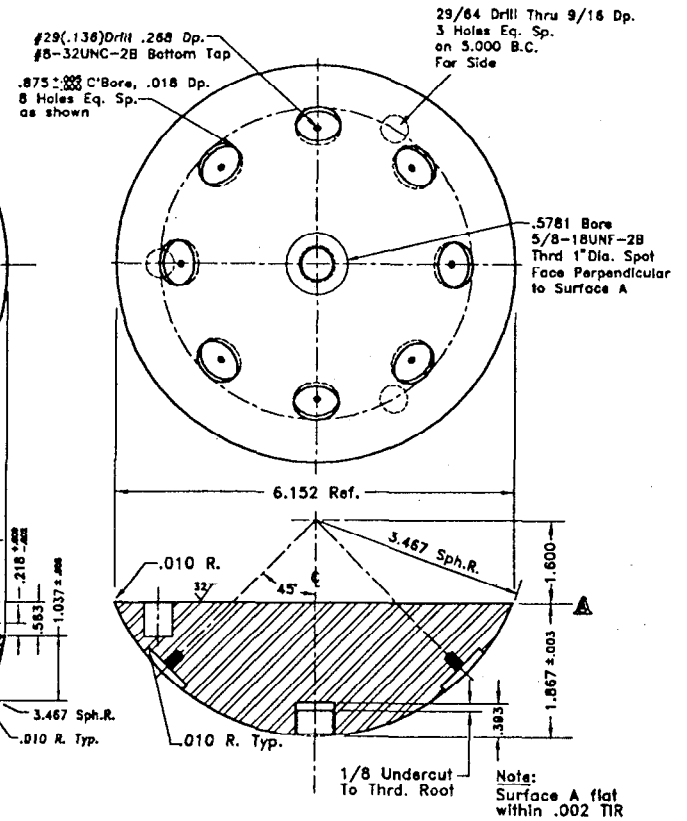

LOWER POLAR CAP
 NOMINAL RADIUS 3.467
 Mat'l: Oracloy

Figure 2 (continued)

Table 4 - Measured Radial Dimensions at 70° F and Masses of the
3.4420-in.-Radius Uranium Metal Sphere Parts

| Section ^a | Variation from 3.4425-in. Radius ^b (10 ⁻³ in.) | Vertical Height ^c (in.) | Certified Mass ^d (g) |
|----------------------|--|---------------------------------------|------------------------------------|
| Top | +1.2 at pole to -0.5 at bottom | 2.1332 | 11,883.24 |
| Central | +0.8 at top to -0.4 at bottom | 1.8914 | 20,814.95 ^e |
| Bottom | +0.2 at top to +0.8 at pole | 2.8608 | 19,624.59 |

^aThe central section now consists of the central and upper plate pinned together, and the bottom section consists of the lower polar cap and lower plate pinned together.

^bMeasured with a sweep gauge at 70° F at the Y-12 Plant. Near continuous variation between end points. Average radius is 3.4420 in., or 8.7427 cm.

^cThe radius obtained from the sum of vertical heights divided by 2 is 3.4427 in., or 8.7445 cm.

^dThe sum of these certified masses is 52,322.78 g. This mass does not include the 0.129-in.-diam, 4.265- and 2.7545-in.-long filler rod for the 0.136-in.-diam diametral hole, which had certified masses of 17.117 and 11.046 g, respectively, and that of the upper socket, which had a mass of 64 g. The total Oralloid mass is 52,414.94 g, which includes the uranium of the socket (64 g) for attaching the upper polar cap to its piston rod.

^eThis mass is for the central section with the 0.136-in.-diam diametral hole empty.

Table 5 - Oralloid Spherical Critical Mass

| Experiment | Critical mass ^a (kg) |
|---------------------------------------|------------------------------------|
| GODIVA ^a | 52.30 ± 0.16 |
| Shell ^a | 52.36 ± 0.16 |
| 3.4665-in.-radius sphere ^b | 52.88 ± 0.11 |
| 3.4420-in.-radius sphere ^b | 52.94 ± 0.06 |

^aDensity of 18.75 g/cm³; enrichment of 93.8 wt % ²³⁵U. Impurities corrected out.

^bDensity of 18.747 ± 0.005; enrichment of 93.2 wt % ²³⁵U with impurities present.

REFERENCE

1. G. E. HANSEN and H. C. PAXTON, "Reevaluated Critical Specifications of Some Los Alamos Fast Neutron Systems," LA-4208, Los Alamos National Laboratory (1969).